

KOHLER® COMMAND PRO®

6–14 HP Engines



KOHLER®
IN POWER. SINCE 1920.

KOHLER

BUILT TO FINISH EVERY JOB IT STARTS.

This is what it takes to be a PRO. Performance enhancing features like a heavy-duty air cleaner, forged-steel crankshaft, electronic ignition and cast-iron cylinder liner. KOHLER® Command PRO® is the standard for professional-grade power and performance.

KOHLER® COMMAND PRO®

DEPENDABLE OPERATION

- Quad-Clean™ all-season four-stage cyclonic air filter—effective engine protection for tough-and-dirty conditions
- Protects from airborne contaminants that can easily clog traditional air filters

LONGER RUNTIMES

- Large-capacity fuel tank means more time working, less time filling
- Electronic ignition and an advanced combustion system design help reduce fuel consumption

EASIER REPOWERING

- Power or repower your equipment without expensive modifications

ALL-WEATHER PERFORMANCE

- Quad-Clean air filter reconfigures in seconds to recycle engine heat
- Command PRO engine starts effortlessly in all weather conditions, from 0 to 110 degrees

BUILT TO LAST

- Forged-steel crankshafts and tough Stellite®-faced exhaust valves with Tufftride-coated stems and cast-iron cylinder bores
- Oil Sentry™ system automatically shuts engine down in low-oil conditions

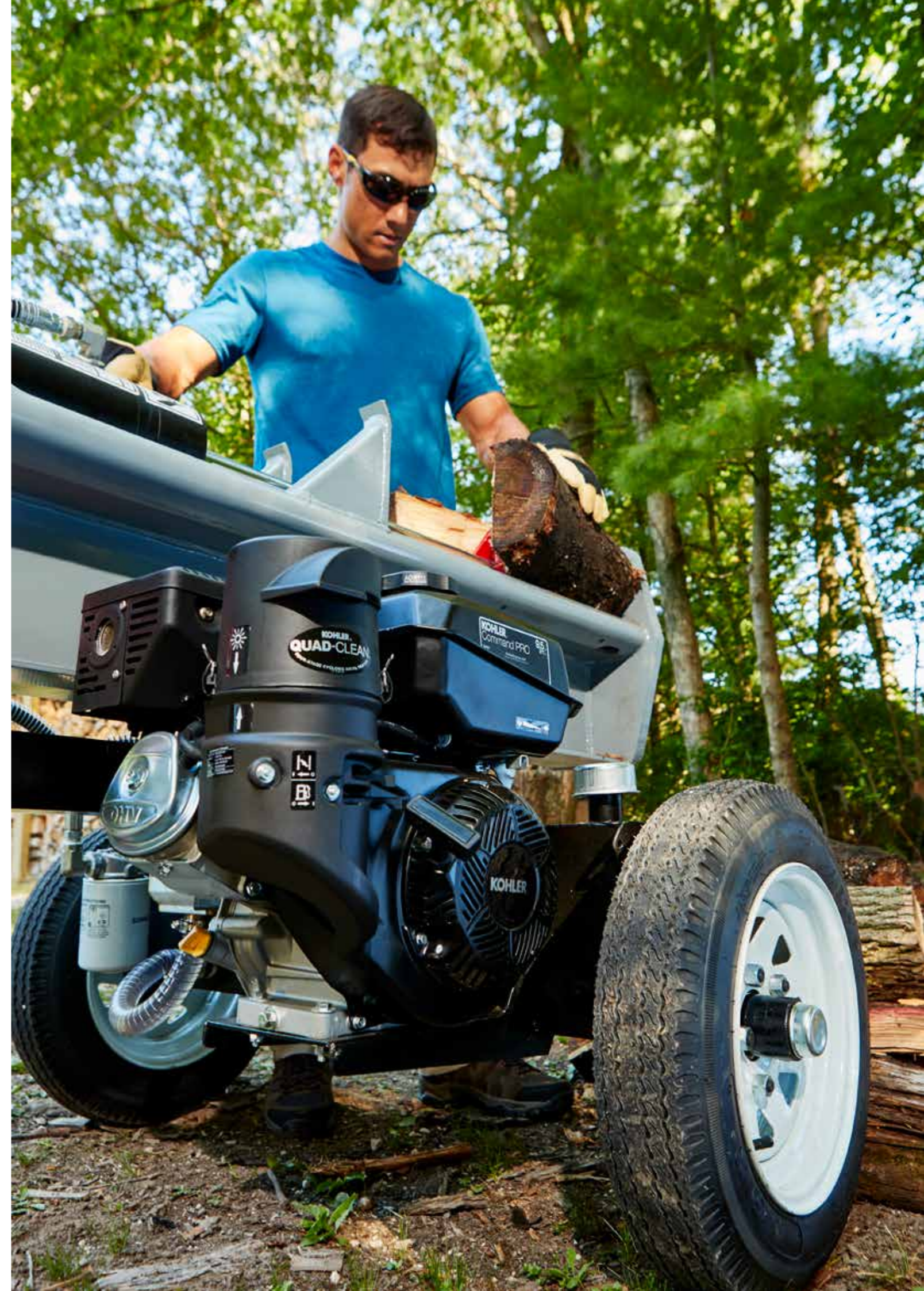

KOHLER® COMMAND PRO®

6-HP Horizontal Shaft Engines

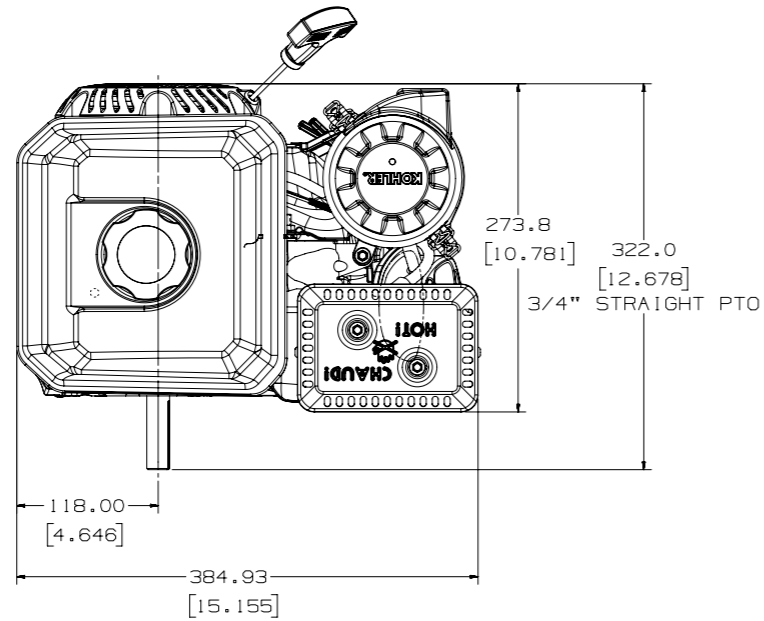

Top view

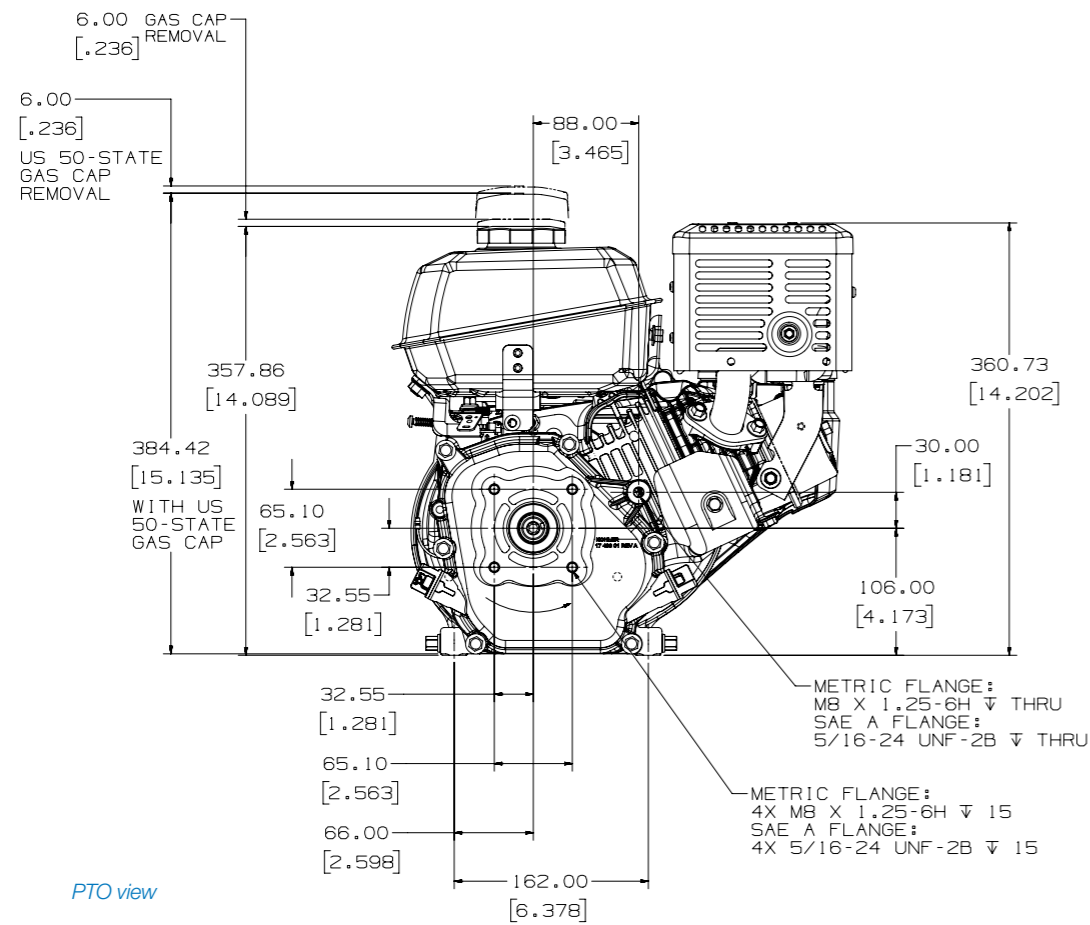

PTO view

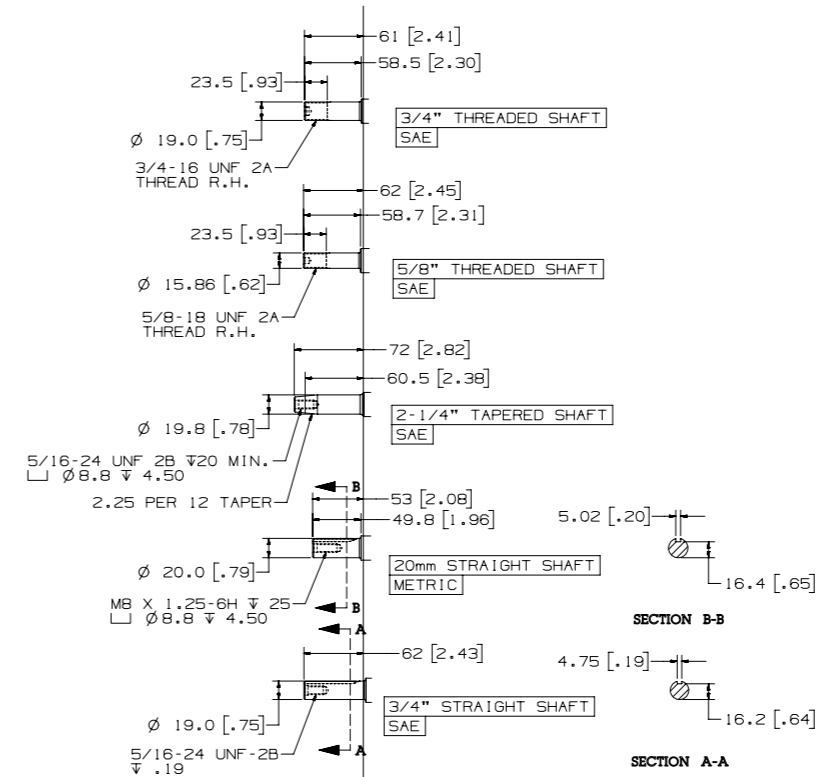

Shaft variations

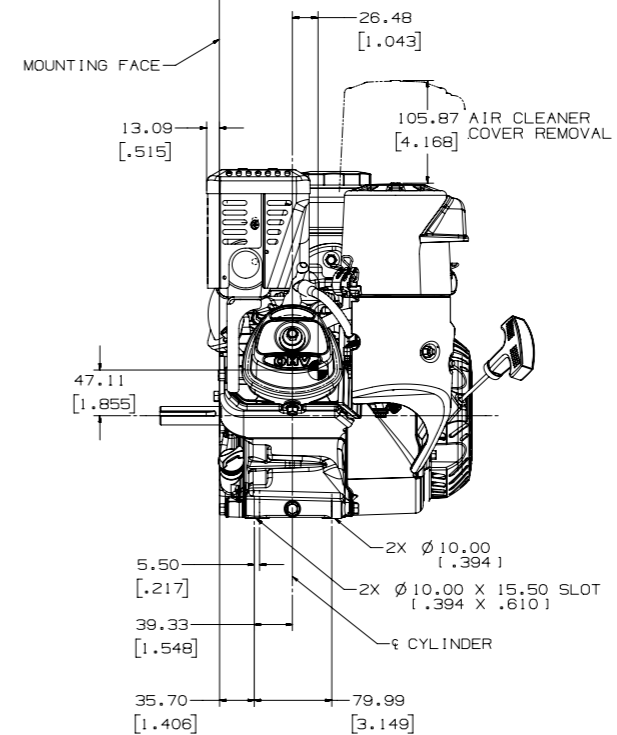

Valve cover view

MAXIMUM POWER

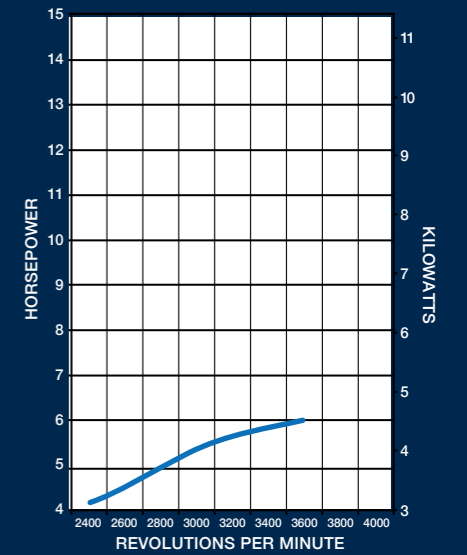

MAXIMUM TORQUE

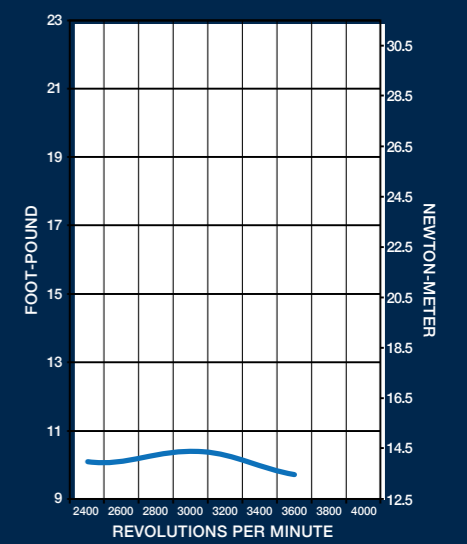

KOHLER® COMMAND PRO®

7-HP Horizontal Shaft Engines

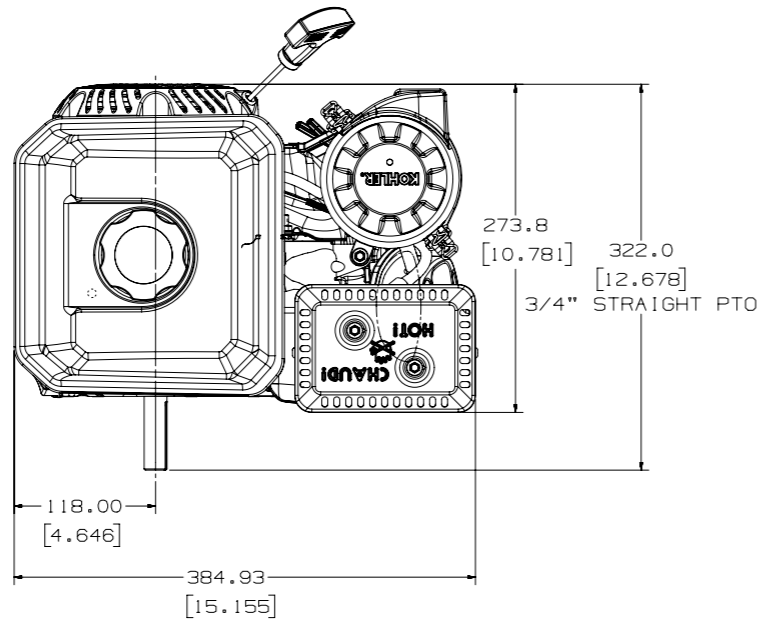

Top view

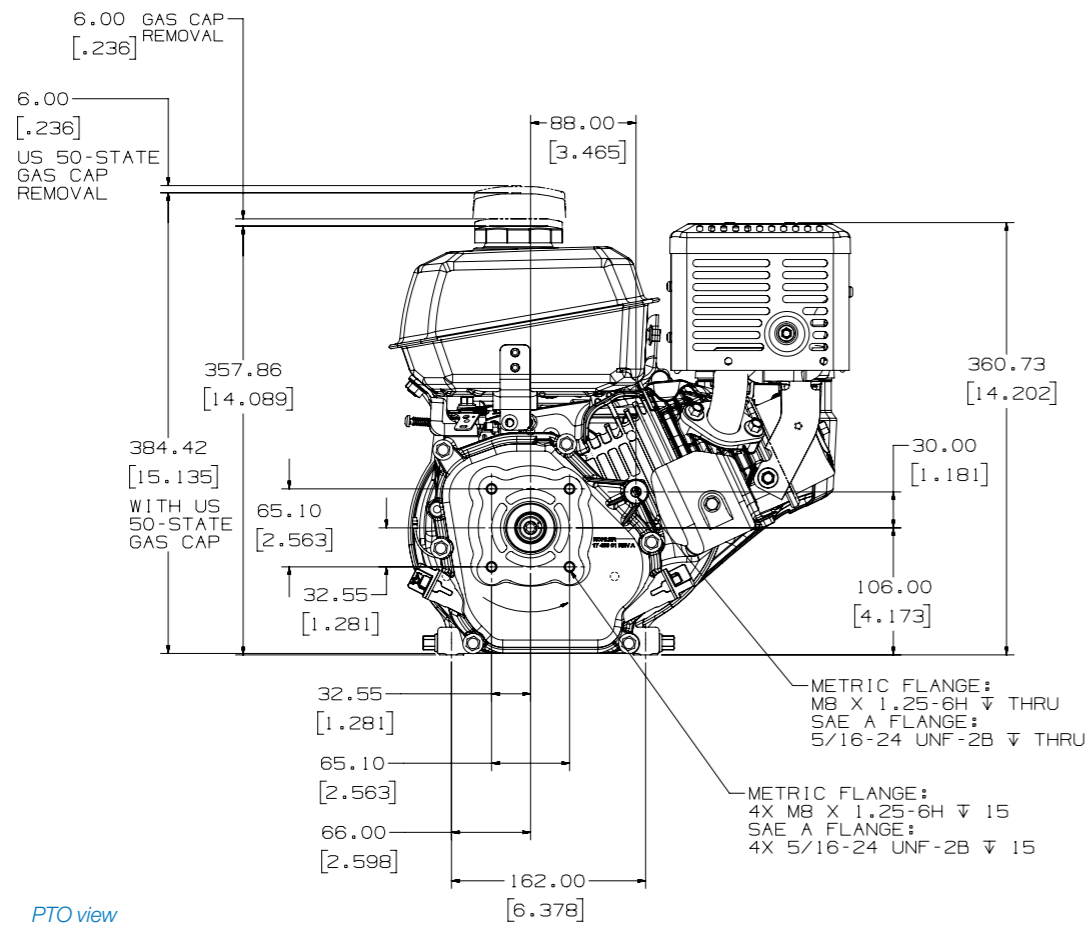

PTO view

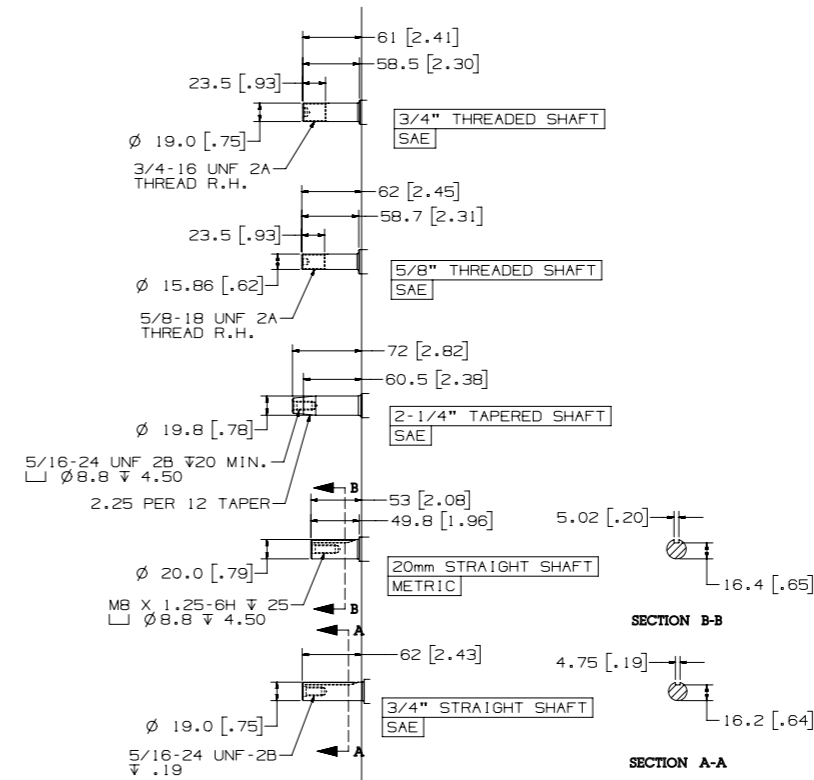

Shaft variations

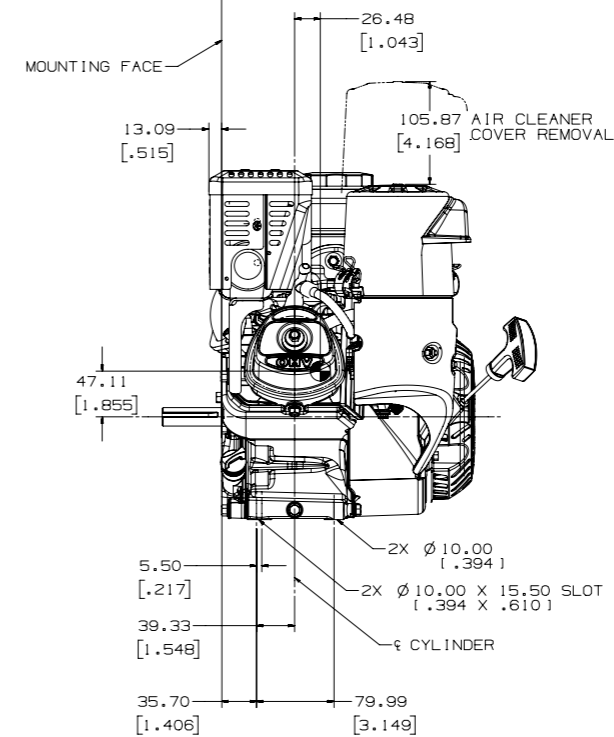

Valve cover view

MAXIMUM POWER

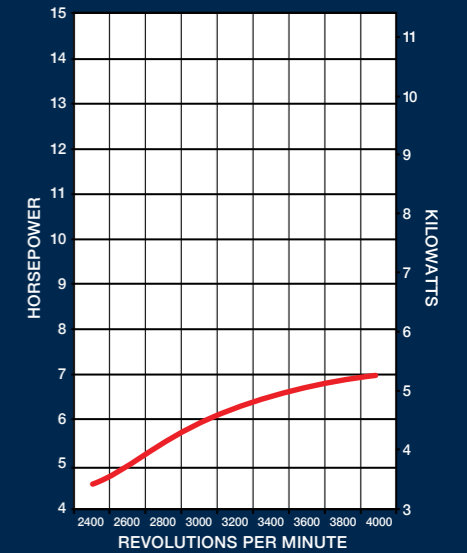

MAXIMUM TORQUE

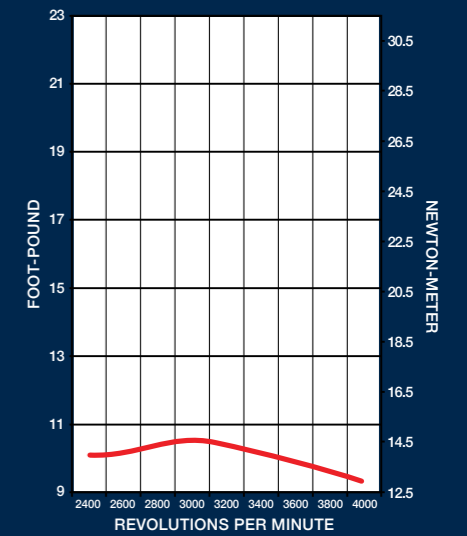

KOHLER COMMAND PRO[®]

9-HP Horizontal Shaft Engines

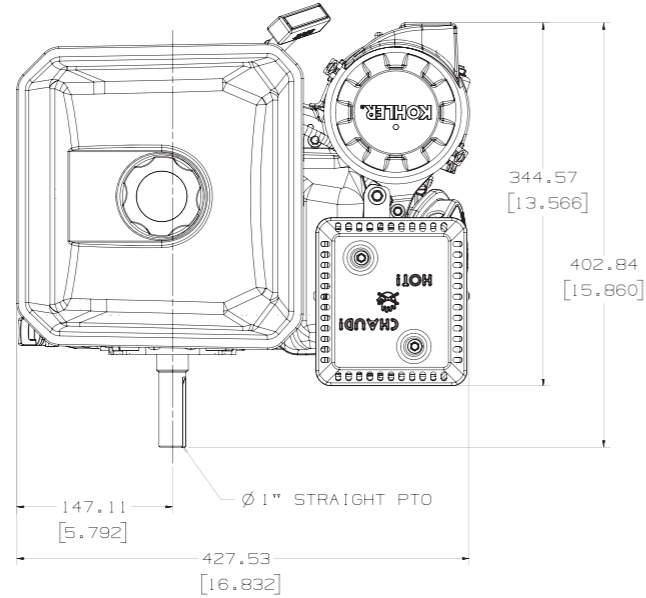

Top view

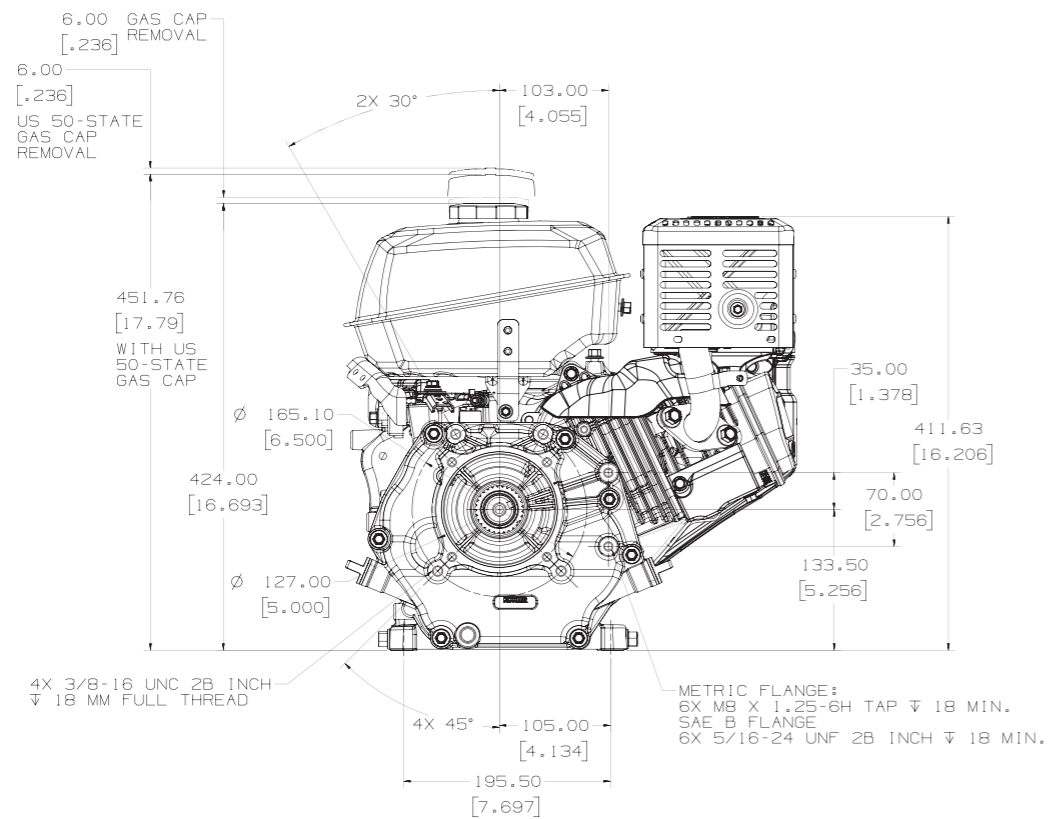

PTO view

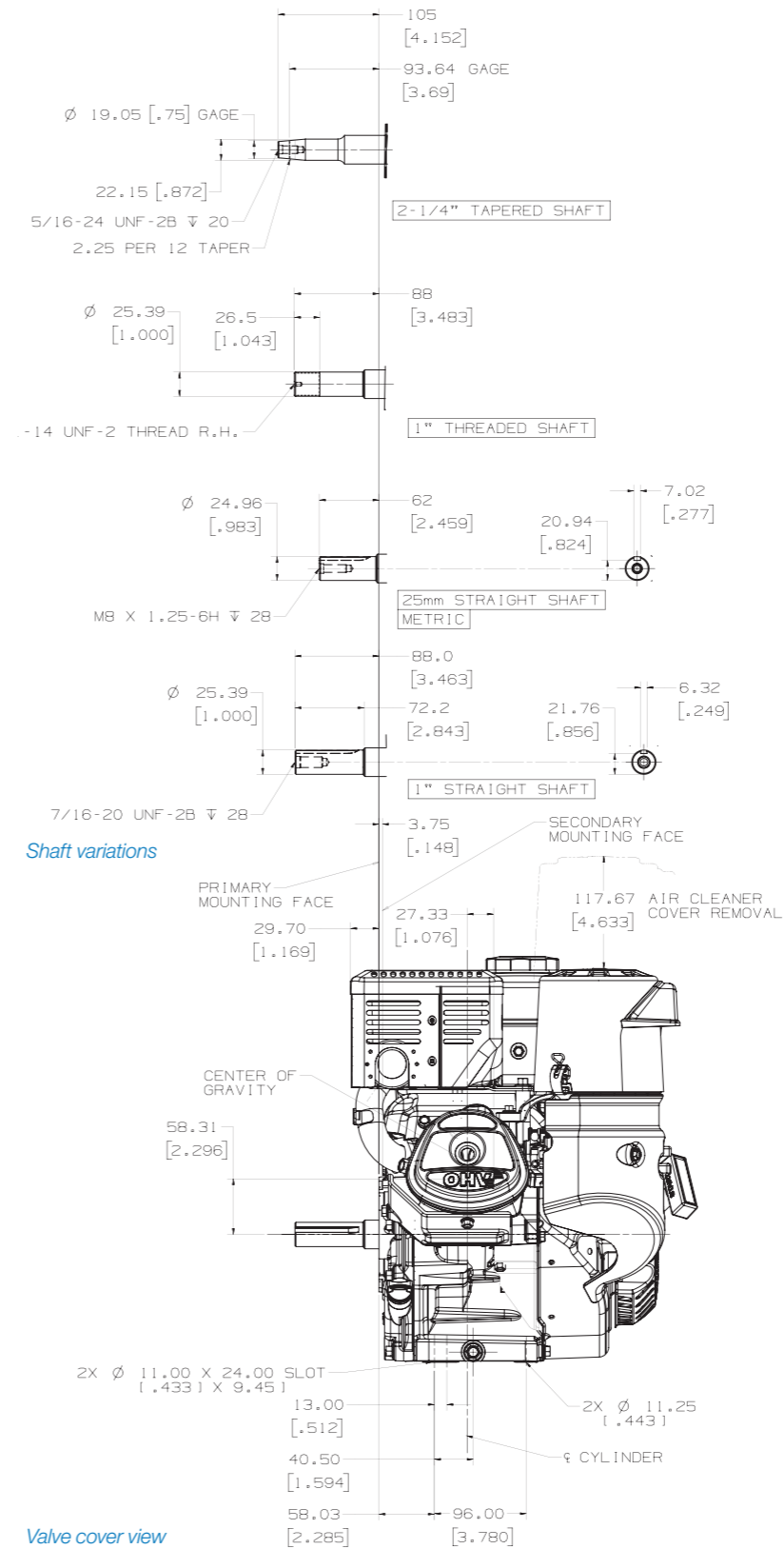

Valve cover view

MAXIMUM POWER

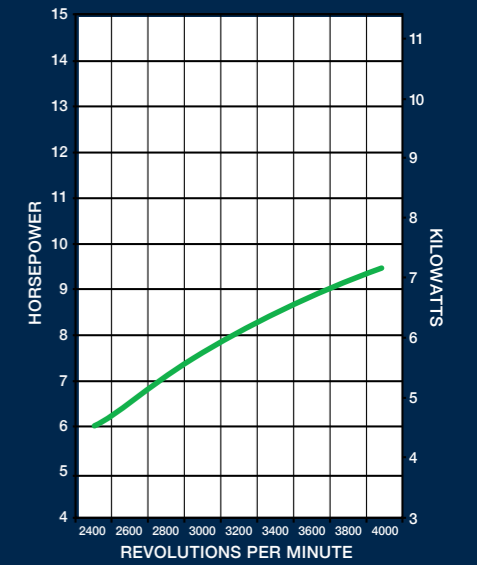

MAXIMUM TORQUE

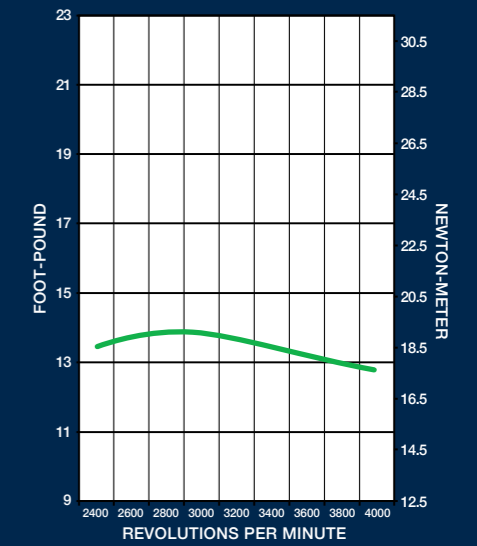

KOHLER® COMMAND PRO®

14-HP Horizontal Shaft Engines

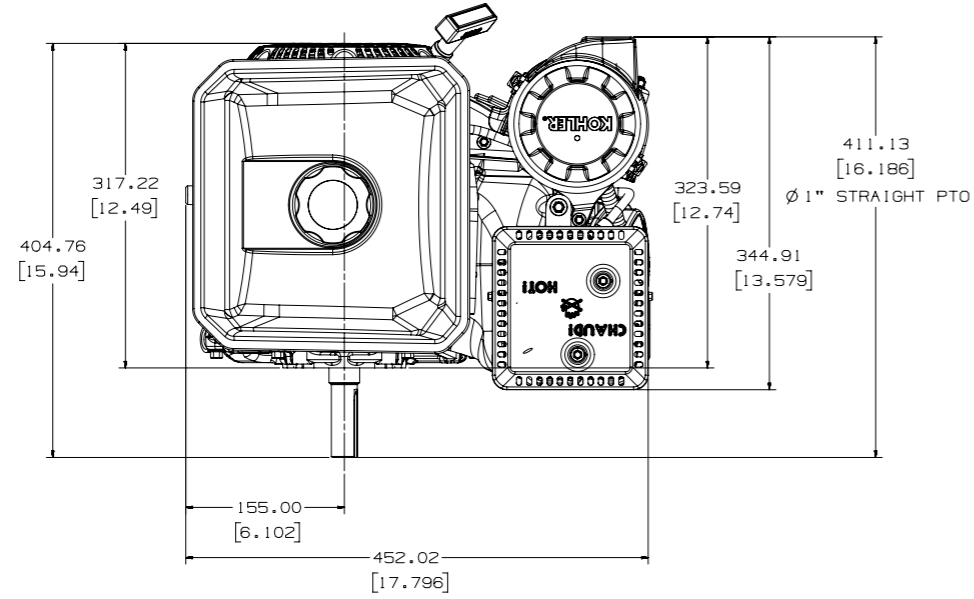

Top view

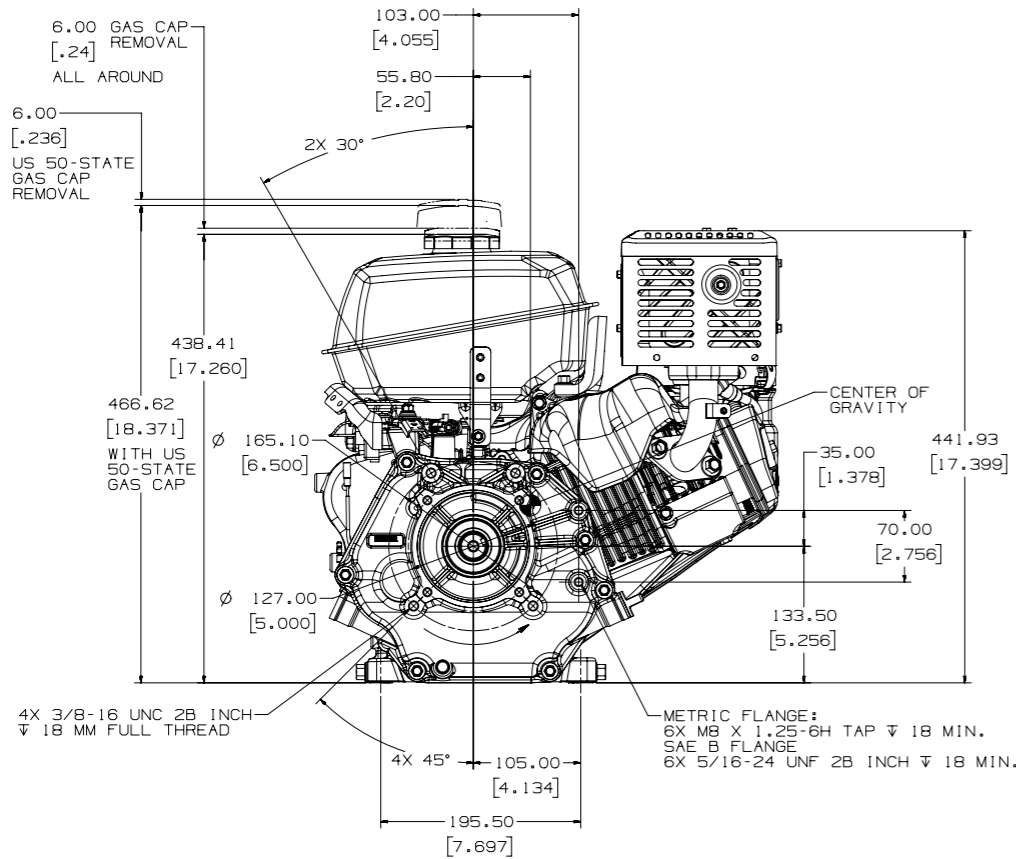

PTO view

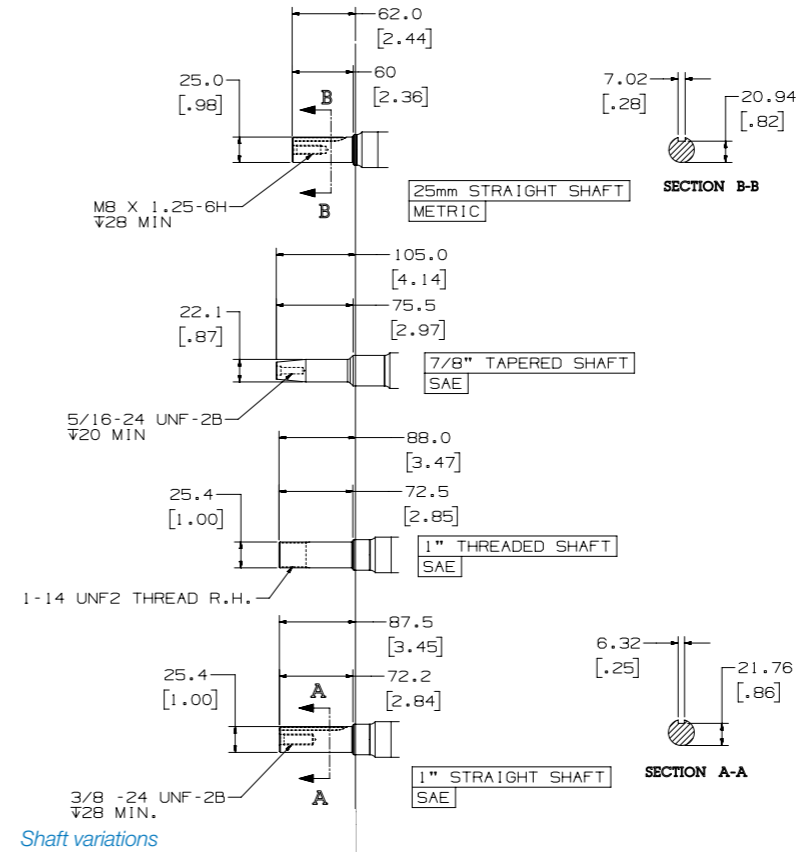

Shaft variations

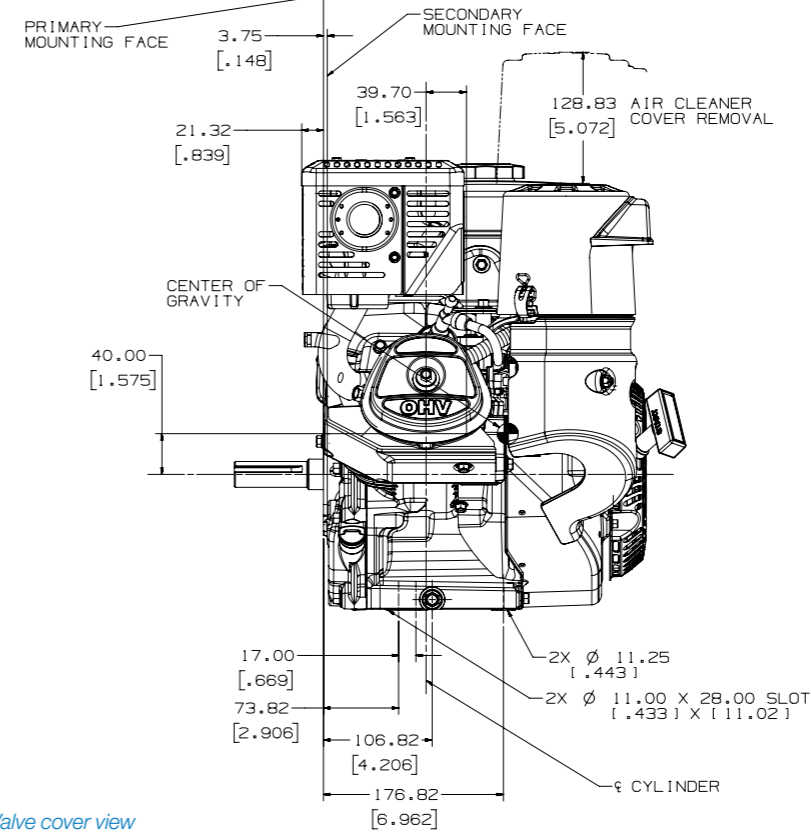

Valve cover view

MAXIMUM POWER

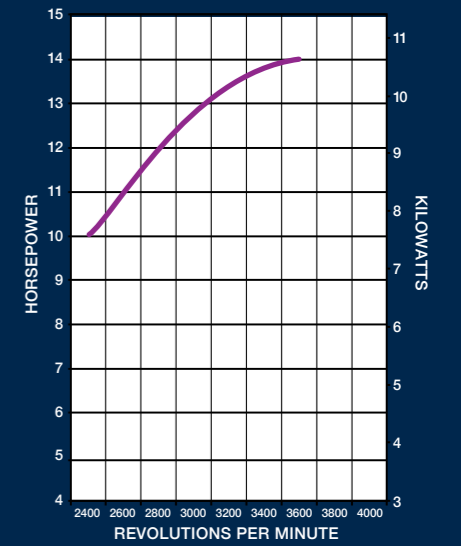

MAXIMUM TORQUE

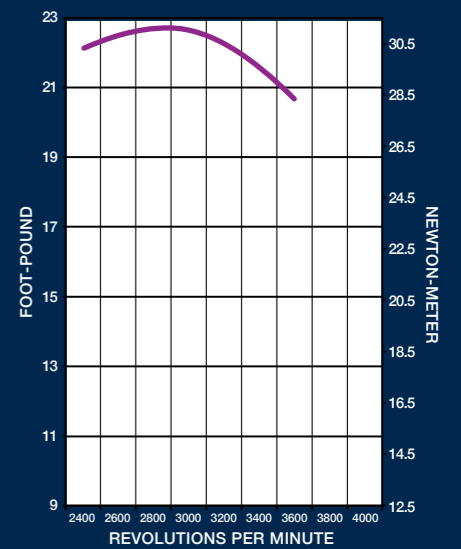

FEATURES AND OPTIONS



CH395

ENGINE TYPE		Four-cycle, single-cylinder, overhead valve, air-cooled, gasoline, horizontal shaft, aluminum head and crankcase with cast-iron cylinder liner.			
MODEL		CH260	CH270	CH395	CH440
GROSS POWER @ RPM*	Max. hp (kW)	6 (4.5) @ 4000	7 (5.2) @ 4000	9.5 (7.1) @ 4000	14 (10.5) @ 3600
DISPLACEMENT	cu in (cc)	12.7 (208)		16.9 (277)	24.7 (429)
BORE	in (mm)	2.8 (70)		3.1 (78)	3.5 (89)
STROKE	in (mm)	2.1 (54)		2.3 (58)	2.7 (69)
PEAK TORQUE @ RPM	ft-lb (Nm)	10.4 (14.1) @ 3000	10.5 (14.2) @ 3000	13.9 (18.8) @ 2800	22.7 (30.8) @ 2800
COMPRESSION RATIO		8.8:1			8.3:1
DRY WEIGHT (RECOIL START)	lb (kg)	38.7 (17.5)		61.5 (27.9)	72.8 (33.0)
OIL CAPACITY	U.S. qt (L)	0.6 (0.6)		1.4 (1.3)	
FUEL CAPACITY	U.S. qt (L)	4.2 (4.0)		7.4 (7.0)	
LUBRICATION		Splash			
DIMENSIONS ¹ L x W x H	in (mm)	10.3 x 15.2 x 15.1 (260 x 385 x 384)		12.4 x 17.8 x 16.8 (315 x 452 x 428)	12.7 x 17.8 x 18.4 (324 x 452 x 467)
CRANKSHAFT HEIGHT	in (mm)	4.2 (106.0)		5.3 (133.5)	

*Horsepower ratings exceed Society of Automotive Engineers Small Engine Test Code J1940. Actual engine horsepower is lower and affected by, but not limited to, accessories (air cleaner, exhaust, charging, cooling, fuel pump, etc.), application, engine speed and ambient operating conditions (temperature, humidity and altitude). For more information, contact Kohler Co. Engine Engineering. Kohler reserves the right to change product specifications, designs and equipment without notice and without incurring obligation.

¹Length is recoil starter to PTO mounting face. Height is with the USA 50 state evap fuel cap.

STANDARD FEATURES

Quad-Clean™ heavy-duty cyclonic air cleaner	Large-capacity muffler with heat shield and spark arrestor	Stellite®-faced exhaust valve	Sound-deadening alloy crankcase
Built-in warm-air system for winter operation	CARB Tier 3 certified	Carbon canister fuel cap	Carburetor bowl drain
OHV slant cylinder	Increased displacement	Water trap to separate moisture in fuel	High-inertia flywheel
Cast-iron cylinder liner	Balance shaft (14 hp)	Swirl-induction combustion chamber	Silenced air intake
Large capacity metal fuel tank	Dual ball bearings	Easy-access throttle, choke and fuel shutoff	Indexable Easy-Pull™ recoil starter
Three fuel filters: fill neck, in-tank and carburetor inlet	Steel-forged-and-hardened crankshaft	Automatic compression release	Fuel Secure™ auto fuel shutoff (basic recoil specs only)
Electronic ignition	Dual oil fills and drains	Automatic low oil engine shutdown system	3-year commercial limited warranty
		Mechanical governor	

POPULAR FACTORY OPTIONS

2:1 gear box (7 hp)	Crankshaft/PTO variations	EMC and Canadian RFI standards	Extended oil fill
2:1 with clutch gear box	No load idle solenoid for fuel economy	EU emissions and noise compliance	Remote throttle
6:1 gear box	Remote throttle	EPA Phase III compliance	Remote choke
High-altitude kits	Carburetor shutdown solenoid	Exhaust deflector	Electronic governor
12-volt starter	Balance shaft 9.5 hp	Low-profile air cleaner	Pulse pump
Exhaust deflector	In-line fuel filter	Low-profile muffler	Purge port for Quad-Clean air cleaner
3-, 10- or 18- (9.5- and 14-hp) amp charging			Tri-fuel capable



“

**MY KOHLER ENGINES
START FIRST-PULL**

EVERY TIME

**AND THAT'S THE BEST
YOU CAN ASK FOR.**

”

AL KINSEY, Owner
Madison Rentals

For more information, contact your KOHLER source of supply.
Kohler Co. reserves the right to make modifications without prior notice.

KOHLER[®]
IN POWER. SINCE 1920.

KOHLERPOWER.IT

Printed in Italy ED0035583570 Rev.03 06/18 Eng KOHLER CO.